

Technical Data

Engine: Air-cooled 4-cylinder engine, 2499 cc,
64 kW (87 DIN HP) at 4000 r/min.
Max. torque 177 Nm (18 kpm)
at 2000 r/min.

Transmission: Fully synchronized 5-speed gear-box and
2-speed auxiliary gear-box. All-wheel drive
and differential locks front and rear
(100 %) to be engaged under load.

Chassis, Suspension: Torsion resistant central-tube chassis
with swing-axles. Coil springs in front,
parabolic leaf springs in the rear plus
rubber hollow springs

Brakes: Dual circuit power brake system. Drum
brakes.

Tyres: Cross-country tyres 245 x 16

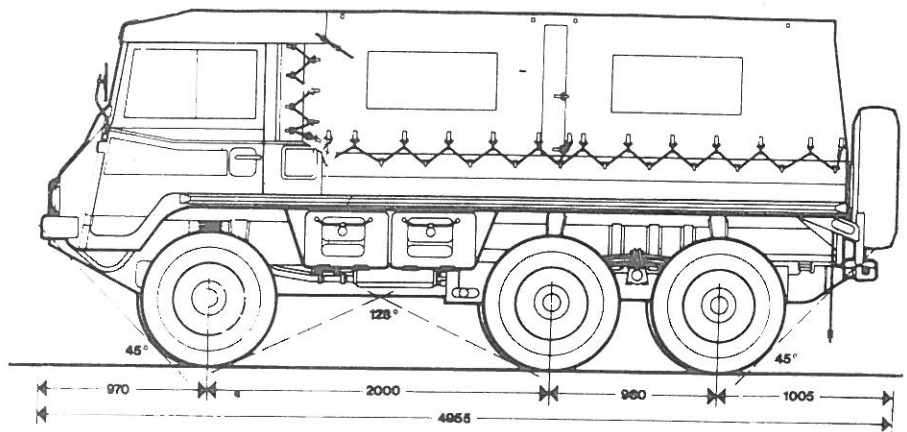
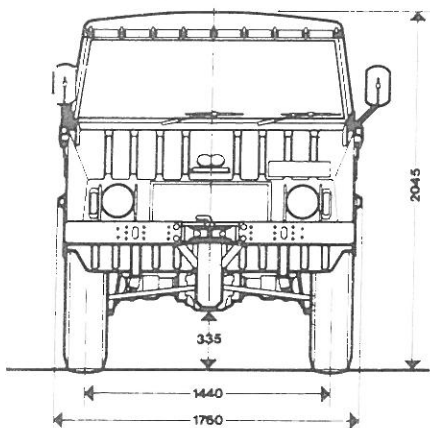

Standard equipment:

- Screen washing equipment
- Fresh-air blower and heater
- 2 exterior rear-view mirrors
- towing device front and rear (5 tons)
with trailer socket
- 2 overroll bars integrated in the superstructure
- Auxiliary gear-box (to be engaged under load)
- All-wheel drive (to be engaged under load)
- Differential lock rear 100% (to be engaged under load)
- Differential lock front 100% (to be engaged under load)
- 75-l fuel tank

Performances:

Climbing ability	100% (loaded)
Ground clearance	335 mm
fording depth	700 mm
Gradient of slope fr/rear	45°/45°
Curb weight (dep. on model)	2350 — 2600 kg
Payload	1500 kg
Axle load front	1450 kg
Axle load rear	2600 kg
Top speed	95 km/h
Minimum speed	2,6 km/h